

142

Soft Serve Freezer

Single Flavor, Taylormate®

Features

Offer all the popular soft serve variations from low or non-fat ice creams to custards, yogurt and sorbet.

Freezing Cylinder

One, 1.5 quart (1.4 liter).

Mix Hopper

One, 8 quart (7.6 liter). Refrigerated to maintain mix below 41°F (5°C) in Auto and Standby modes.

Indicator Lights

The Mix Low light alerts the operator to add mix.

Automatic Temperature Control

Precise temperature control automatically maintains high quality soft serve products.

Standby

During long no-use periods, the standby feature maintains safe product temperatures in the mix hopper and freezing cylinder.

Merchandising

Yogurt and Soft Serve magnetic decals with a set of 16 flavor pads.



Standard 6



SA2650

Selected 50
Hz. Models

142 Soft Serve Freezer

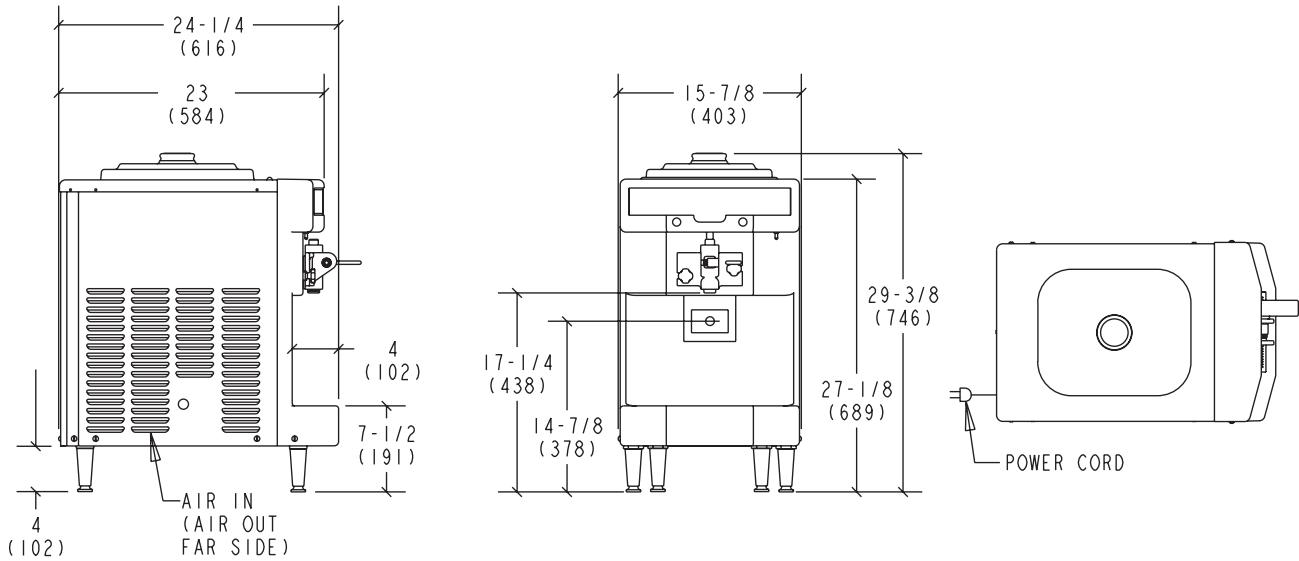

NOTE:
FIGURES IN PARENTHESES
INDICATE MILLIMETERS.

Weights	lbs.	kgs.
Net	180	81.8
Crated	209	94.9
	cu. ft.	cu. m.
Volume	10.7	.30

Dimensions	in.	mm.
Width	15-7/8	403
Depth	24-1/4	616
Height	29-3/8	746
Counter Clearance	4	102

*Mounted on standard legs

Electrical	Total Amps	Supplied with NEMA Cord
115/60/1 Air	15.0	5-20P
208-230/60/1 Air	9.4	6-15P
220-240/50/1 Air	9.1	----

*This unit may be manufactured in other electrical characteristics. Refer to the local Taylor Distributor for availability.
(For exact electrical information, always refer to the data label of the unit.)*

Bidding Specs

Electrical: Volt _____ Hz _____ ph _____
Neutral: Yes No Cooling: Air Water NA

Options: _____

Specifications

Electrical

One dedicated electrical connection is required. See the Electrical chart for the proper electrical requirements. Manufactured to be cord connected. Consult the international Taylor distributor for cord & receptacle specifications for 50 Hz. equipment.

Beater Motor

One, 0.5 HP.

Refrigeration System

One, 3,000 BTU/hr. R404A.
(BTUs may vary depending on compressor used.)

Air Cooled

Minimum 6" (152 mm) on both sides. Install the skirt provided on the right side of the unit and place the back of the unit against a wall to prevent recirculation of warm air. Minimum air clearances must be met to assure adequate air flow for optimum performance.

Options

- Cone Dispenser
- Mix Low Chime

Continuing research results in steady improvements; therefore, these specifications are subject to change without notice.



Taylor Company,
A Division of Carrier Commercial Refrigeration, Inc.
Rockton, Illinois 61072
815-624-8333 800-255-0626 Fax 815-624-8000
www.taylor-company.com

Printed in U.S.A.
039977-ADV 3/05