

# Broaster® To Go Authentic Pizza Countertop Refractory Oven



- **Solid Construction** – Durable stainless steel construction ensures that this robust unit will become the workhorse of your operation.
- **Easy Operation** – Simple and straight-forward operation makes cooking the perfect pizza nearly foolproof.
- **Convenient** – This super compact unit fits on almost any countertop and is stackable up to four high to accommodate future growth of your pizza business.
- **Dual Temperature Zones** – Individual control of the top and bottom heating elements provides the ability to cook precisely to your preferences.
- **Speed** – Two heating elements, working in combination with each other, provide cooking times as low as 6 minutes per frozen pizza.



*The Countertop Refractory Oven is a fast, economical, and convenient way to offer great tasting pizza to your customers in a matter of minutes.*



# Broaster® To Go Authentic Pizza Countertop Refractory Oven

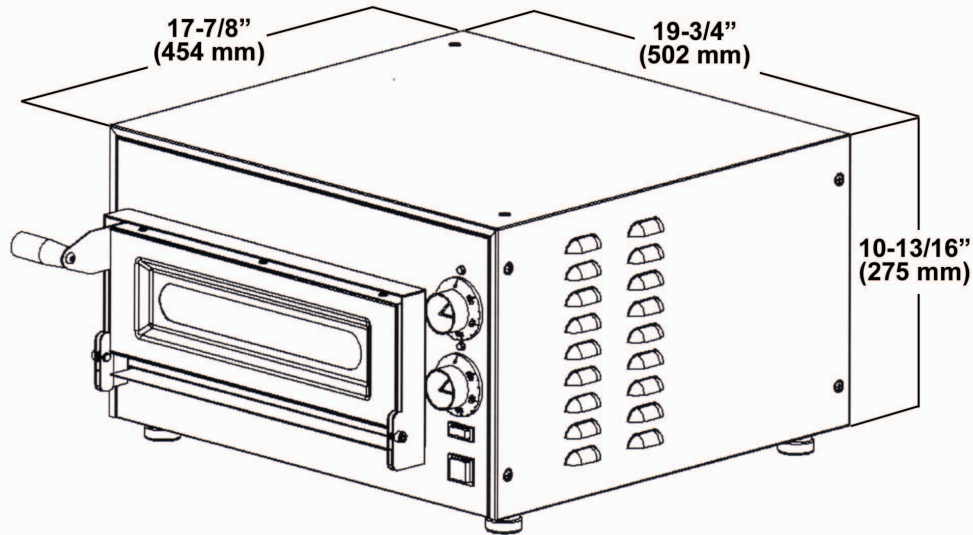

## SPECIFICATIONS

OUTSIDE DIMENSIONS			INSIDE DIMENSIONS			WEIGHT	MAX TEMP
W	D	H	W	D	H		
19-3/4" (502 mm)	17-7/8" (454 mm)	10-13/16" (275 mm)	13-3/4" (349 mm)	13-3/4" (349 mm)	3-1/8" (79 mm)	53 lbs. (24 kg)	750°F (400°C)

## ENERGY REQUIREMENTS

115 V, 1 Phase, 50/60 Hz, 12.7 Amps

## ADDITIONAL FEATURES

- Separate manual temperature controls for top and bottom heating units
- Bottom heating unit encased in a specially designed refractory stone
- Leveling feet adjustable up to 1.6"
- Observation window in the door
- Interior light

*Broaster offers a wide range of top-quality pizza baking equipment including the Lincoln air impingement oven, the Broaster Model 120 convection oven, and the Moffat Model E25, E25B, and E311 MS convection ovens!*

