

THE BROASTER COMPANY

Prep Stations

An American Tradition Since 1954!

Extra Crispy High Volume
Prep Station



- These stainless steel prep stations are designed to help make your breading process more efficient by giving you a mobile area to prepare your Extra Crispy Broaster Chicken® or Genuine Broaster Chicken®.
- The prep stations are the perfect accessory to minimize your waste, by helping you control your breading usage.
- Sturdy, stainless steel work surfaces are durable and easy to clean after use.

* Buckets and holding pans for the Extra Crispy Prep Station are sold separately.

The Broaster Company

2855 Cranston Road, Beloit, WI 53511

(800) 365-8278 • (608) 365-0193

Fax (608) 363-7957 • www.broaster.com



THE BROASTER COMPANY

Prep Stations

85405 Extra Crispy High Volume Prep Station

This prep station is designed for a higher volume operation or an operation that is looking for more efficient use of their breadings. The prep station has a built-in sifter which allows you to sift breading into the lower container, thus giving you more efficient use of your breadings. The containers also include lids to help reduce the risk of contamination. The extension shelves on this unit make it easier to bread and load product into the Broaster pressure fryer.

Includes: One basic station, two extension shelves, one pan shelf, rotary sifter, two 12.5 gallon tubs, one caster kit, four swivel casters - two locking

Options: Leg kit, right side shelf without hole, 12 quart bucket & lid

DIMENSIONS

Width	28 3/4" (730.3)
Depth	20 3/4" (527.1)
Height to table top	36" (914.4)
Height overall	54" (1371.6)
Width overall	56 3/4" (1441.5)
Shipping Weight	105 lbs.

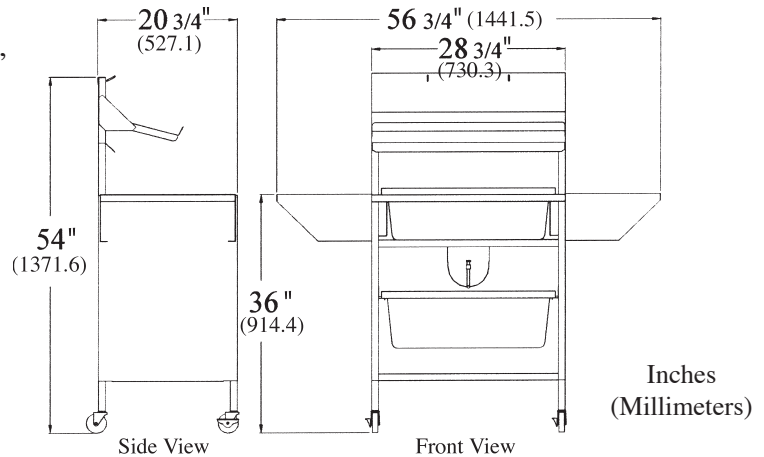

11853 Basic Prep Station

Extra Crispy High Volume Prep Station excluding the extension shelves and one pan shelf.

85837 Extra Crispy Prep Station

This prep station features a smaller footprint, allowing you to put this prep station almost anywhere. It could be put right on the line or be rolled back into a walk-in refrigerator to refrigerate the coating and slurry. The prep station is also complete with two tray slots for additional pan storage.

Includes: One basic station, four swivel casters - two locking

Options: 12 quart bucket & lid, holding pans

DIMENSIONS

Width	25 5/8" (650.8)
Depth	16 1/8" (409.5)
Counter Height	36" (914.4)
Shipping Weight	58 lbs.

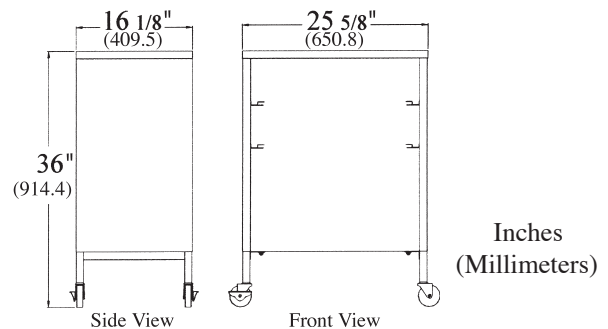

15416 Broaster Extra Crispy Breader Kit

This accessory kit is ideal for use with the Extra Crispy Prep Station. The kit includes everything you need to prepare Extra Crispy Chicken including a sifter for more efficient use out of your breadings.

Kit Includes: wire whip, sifter, 1 cup measuring cup, pitcher, 12 quart bucket & lid, 12 quart breading box & lid, and disposable foodservice gloves



The Broaster Company

2855 Cranston Road, Beloit, WI 53511

(800) 365-8278 • (608) 365-0193

Fax (608) 363-7957 • www.broaster.com

